

Wiring Diagram

PCB Rev E

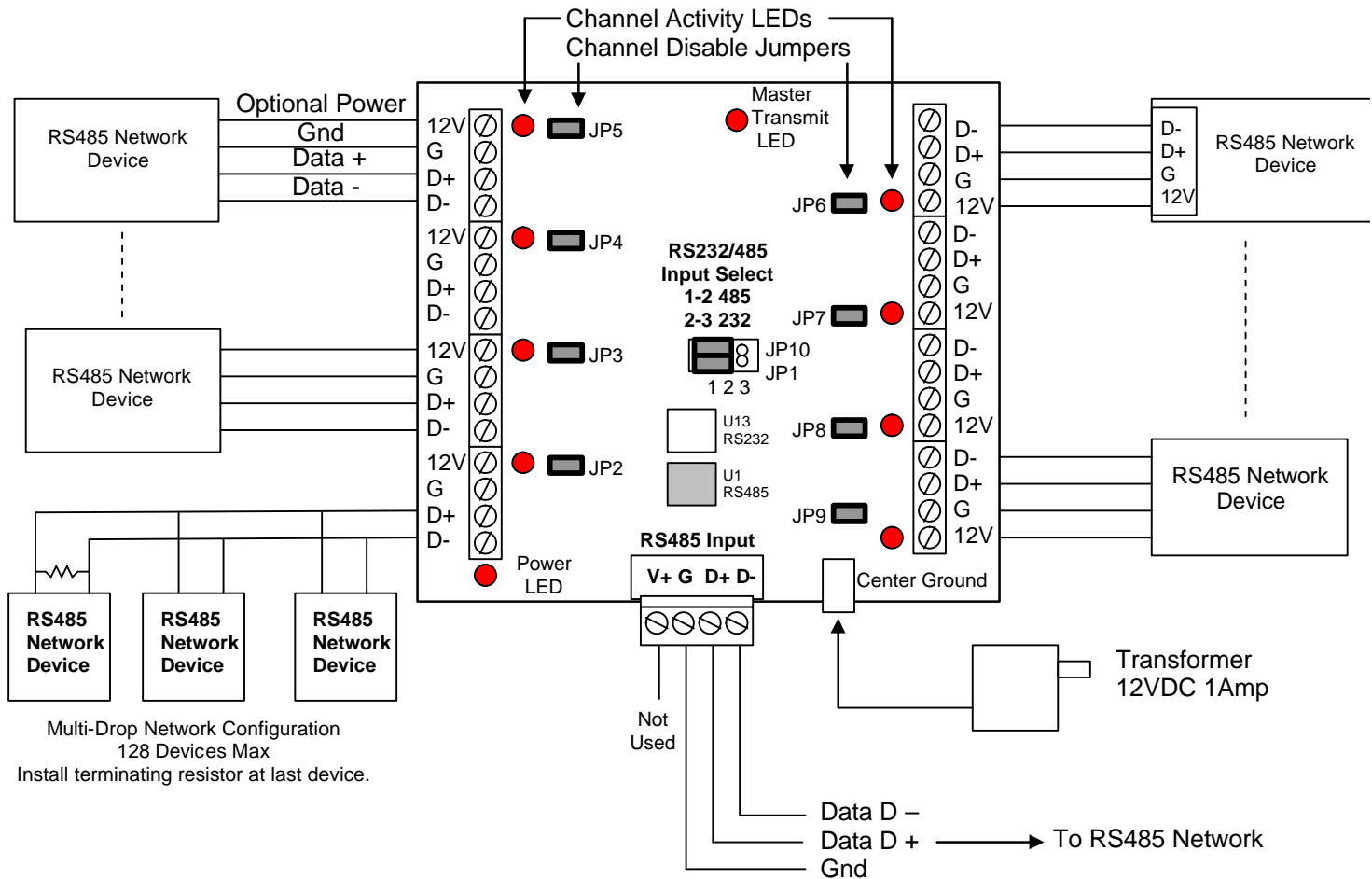

Active Hub Channels

Each channel on the hub is driven by its own RS485 driver IC. Each channel can support 128 devices and a maximum line length of 4000 ft. Active transmission control is provided by the hub for outbound messages from the Master input. All channels transmit simultaneously.

Star Wiring Topology

The hubs are designed to allow trouble free point to point star wiring topologies, without regard for line length or termination. However, each hub channel can support single device or multi-drop configurations with proper network considerations.

Network Power

Network devices may be powered from the hub's 12VDC @ 200mA max. **Each channel is protected by a re-settable 200mA fuse.** Do not exceed maximum power draw for all devices of 1000mA. Power input to the hub is protected by a re-settable fuse.

RS232/485 Input Jumpers

Jumpers JP1 and JP10 select the hub input source type.

For RS485 Input: Set JP1 and JP10 jumpers to positions 1 and 2.

For RS232 Input: Set JP1 and JP10 jumpers to positions 2 and 3.

NOTE: Correct driver IC must be installed for input selected. U1=RS485 (MAX487E), U13=RS232 (DS275).

Channel Disable Jumpers. JP2,3,4,5,6,7,8,9. To isolate a channel from affecting hub operation, remove the channel jumper. This disables communication on that channel.

Channel Termination

Termination resistors (120 Ohm) are generally recommended on line lengths over 100 ft. Each channel has a termination resistor on board.

For SINGLE device connection to a channel, a terminating resistor should be on the device end also.

For MULTI-DROP connection to a channel, a terminating resistor should be installed on the last device on the line.