

## Overview

RCS communicating Thermostats and Zone Controls consist of two parts. The Wall Display Unit (WDU) and the HVAC Control Unit (CU). The Wall Display Unit looks and functions like a traditional thermostat with a display, buttons and a temperature sensor. The HVAC CU actually contains all the thermostat logic, the HVAC output relays and the communications port.

This unique two-part design allows for several advantages when installing communicating thermostats.

First, **no new wires** are required to be run to the “thermostat” location on the wall. In retrofit installations, the existing thermostat wires can be used. Simply install the WDU in place of the old thermostat and the CU inline anywhere along the thermostat wire back to the HVAC system.

Second, solves the **no power at the thermostat** problem. Since the connection from the WDU to the CU is now an intelligent digital communications link, both **power and data** can be provided to the WDU location over the **existing wires**. Because no power is typically provided by traditional one piece thermostat direct wiring, this makes other communicating thermostats require costly additional wires and the lack of power prevents features like graphical displays and always on backlights.

Third, **convenient wiring at a convenient location**. The network connection, the outside sensor and other connections are made at the CU, which is typically mounted at or near the HVAC system (or anywhere YOU deem convenient). This is much easier than running them up inside the walls to the thermostat location. **Plus many new features** such as ventilation control, energy management functions and monitoring the health and status of the HVAC system can be added without requiring more wires as would be required by a one piece wall mounted thermostat.

Fourth, **cost saving and fully integrated zoning**. When two or more zones are used, the single CU (only one required for up to 6 zones) with multiple low cost WDU's eliminates costly duplication of the HVAC control outputs and provides for an intelligent integrated control in one unit. This is the only solution that provides for all the zone information (temperatures, setpoints and modes) to be used by the zone controller and available on the network.

TR series Thermostats have fully opto-isolated RS485 network ports. These ports require an isolated network 12VDC power source (thermostat power is provide by the HVAC system). RCS controllers and hubs provide this. Third party controllers may require an additional power supply if they cannot supply the 12VDC.

### TR16 Thermostat Installation Block Diagram

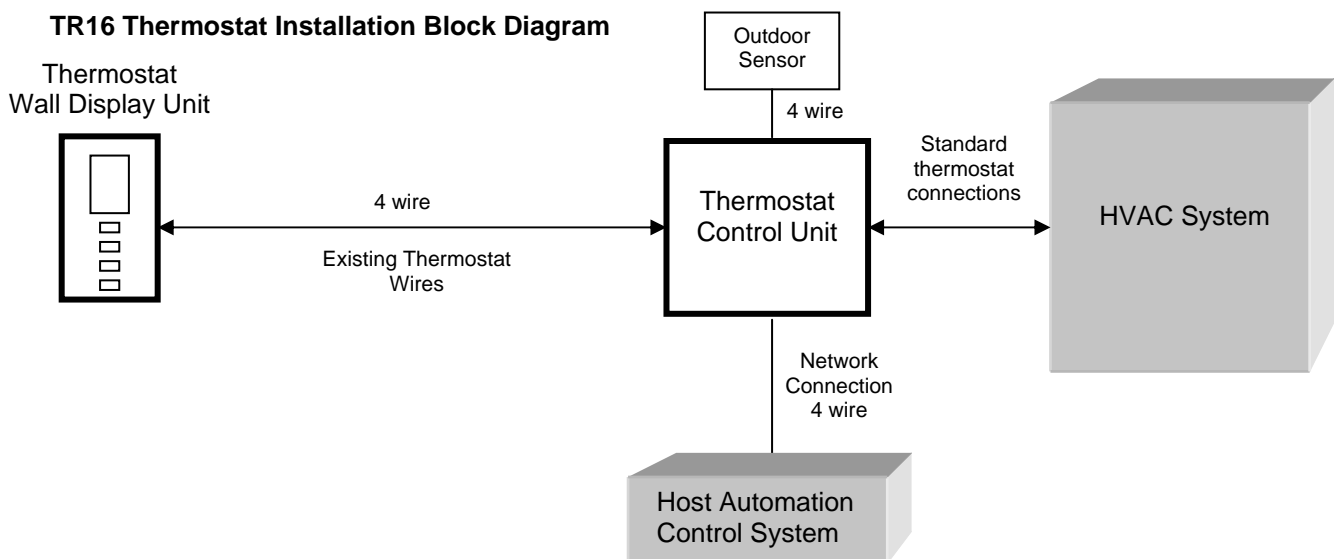

## Direct RS485 Communications

### Wiring to RCS CommStar or Stargate Network Control Units

RCS CommStar or Stargate Controllers have RS485 com ports that can wire directly to TR series Thermostats using a 4-wire connection as shown below. The TR series Thermostats have an opto-isolated RS485 port that requires 12 Volts DC network power, the CommStar/Stargate controllers can provide the isolated 12 VDC power required by the network.

If more than one device is connected to the RS485 network, an RS485 hub (Model 8AH485) is recommended.

The RCS Model CS308 Controller contains a built-in 8 channel RS485 hub, the other CommStar/Stargate type controllers require the use of an external RS485 Hub, Model 8AH485.

Refer to the installation instructions provided with the controller. Watch total power consumption if more than one RS485 device is connected to the controller.

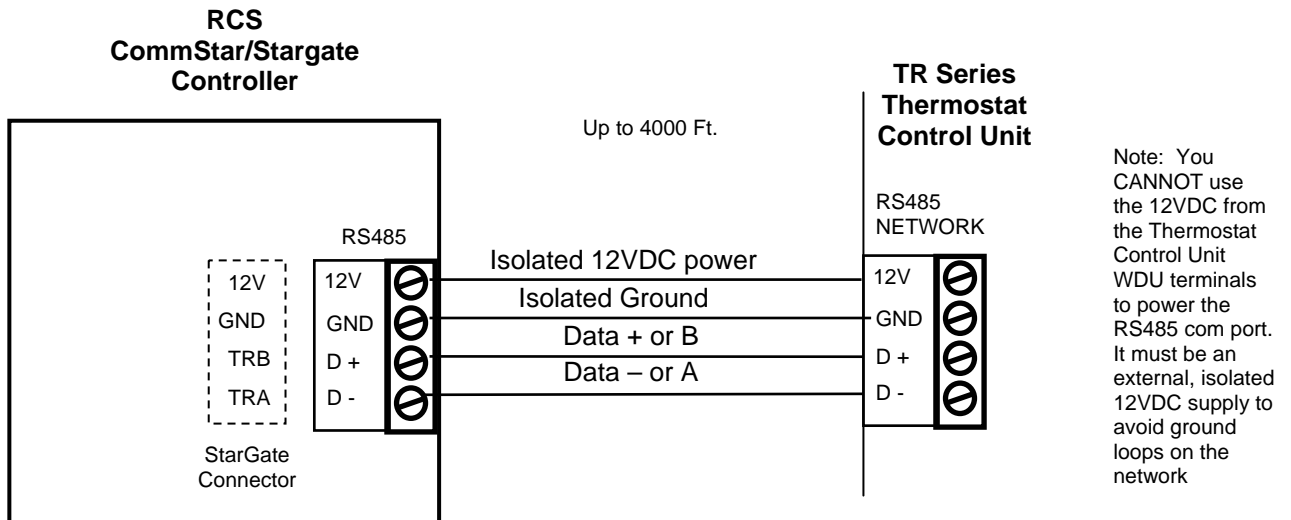

### Wiring to other Control System's RS485 ports

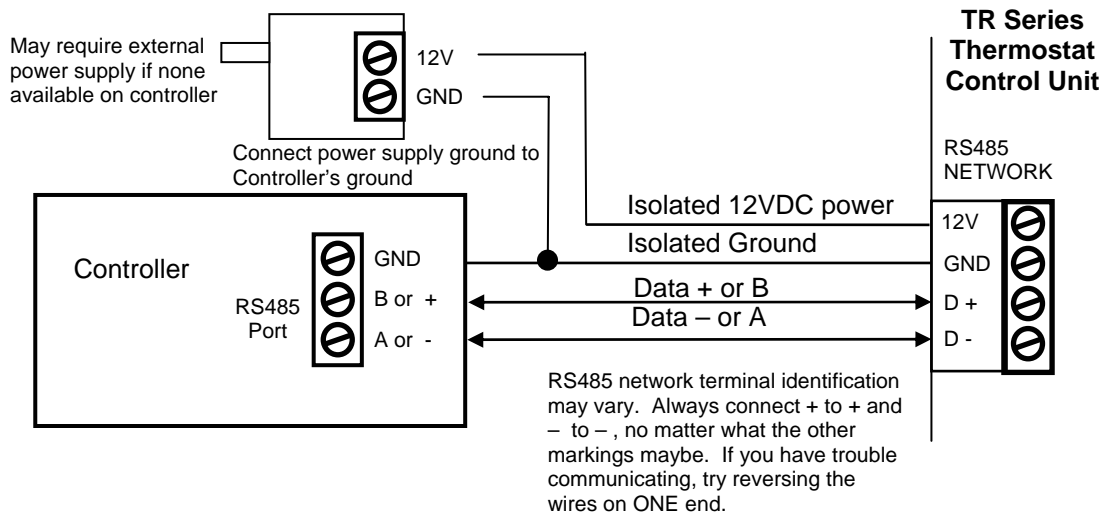

## RS232 to RS485 communication with converters

### Wiring to PCs or other controllers with RS232 Com ports

When connecting the TR series thermostats to a PC or other controller using serial RS232 com ports, an RS232 to RS485 converter **is required** to connect to the thermostat's RS485 com port.

**Opto – Isolated Network RCS** TR series thermostats have an opto-isolated RS485 port. The RCS RS232 to RS485 converters provides the isolated power for the network.

Two types of RS232 to RS485 converters are available from RCS:

**Model 485PB 1 – 2 thermostats on a shared RS485 port.** For single or multiple thermostat applications with simple and short wiring, this low cost converter can be used. It has a RS232 to RS485 converter and common RS485 ports with terminal blocks. Provides isolated 12VDC power.

**Model 8AH232 1 – 8 thermostats on a star wiring RS485 active hub.** Provides a RS232 to RS485 converter and 8 independent RS485 ports for a robust network with no wiring or termination restrictions. Provides isolated 12VDC power. Additional RS485 hubs (Model 8AH485) can be added for a total of 64 ports.

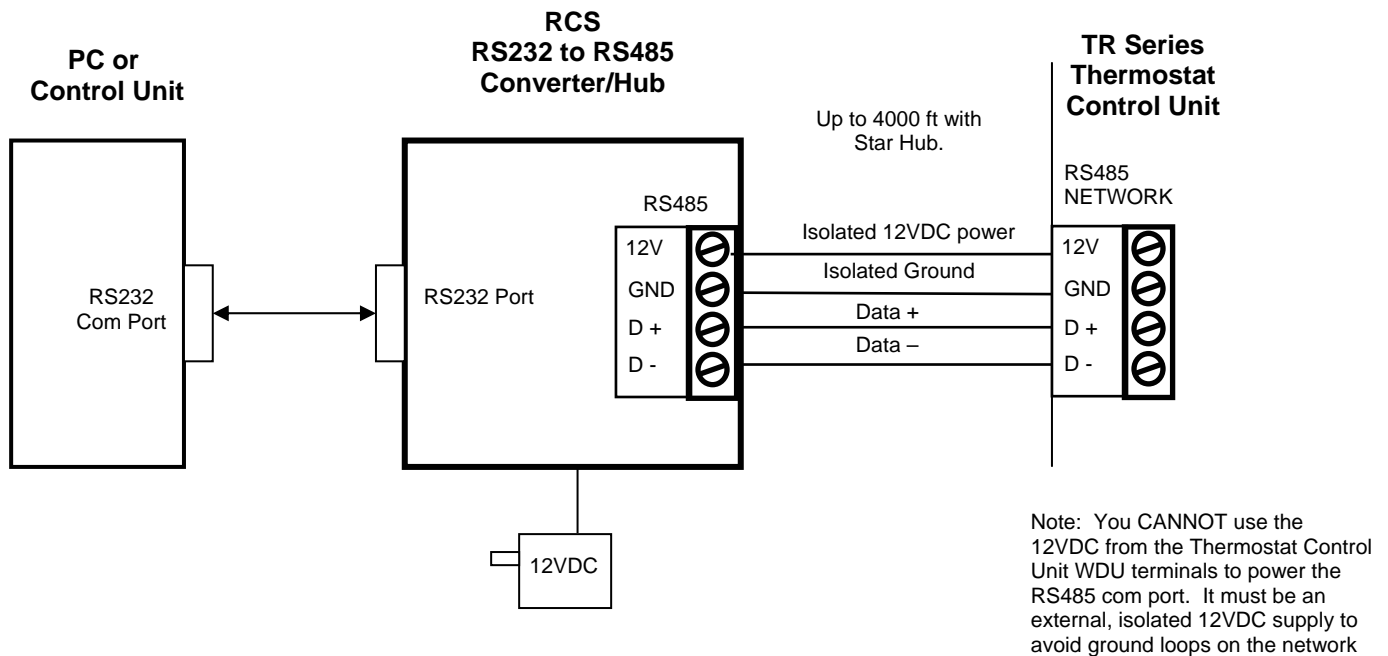

Refer to the installation instructions provided with the converter. Watch total power consumption if more one RS485 device is connected to the converter.

## Model 485PB RS232 to RS485 Converter

The 485PB has an RS232 serial input and a shared RS485 port with outputs connectors and network power supply for the thermostats isolated network ports

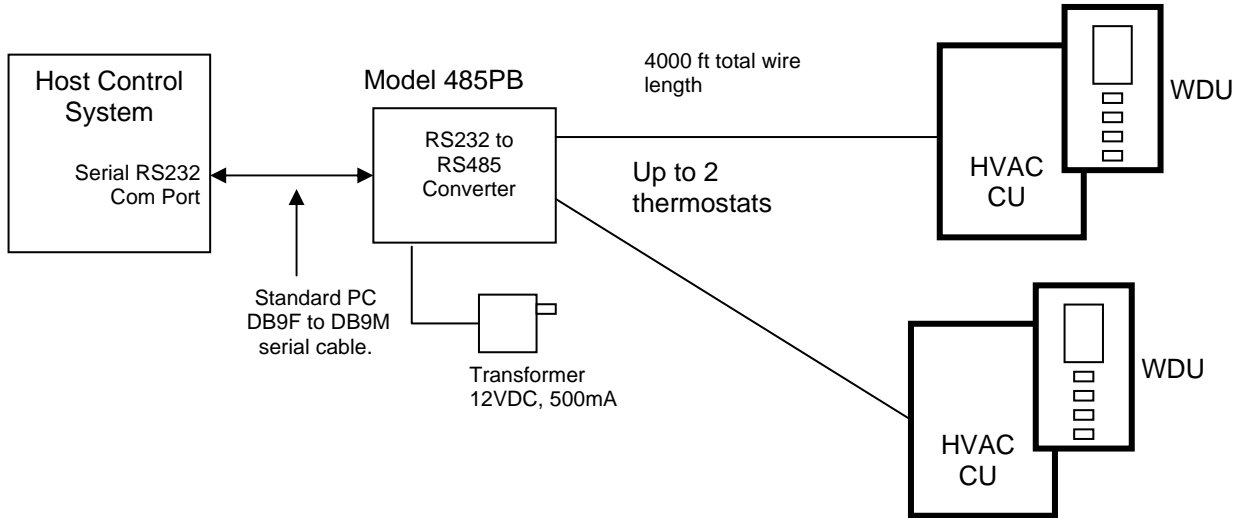

## Model 8AH232 RS232 to RS485 Converter and 8 Channel Star Wiring Hub

The 8AH232 is an eight channel active hub. It has an RS232 serial input and 8 individual RS485 ports. Network power is provided for the isolated thermostat network ports.

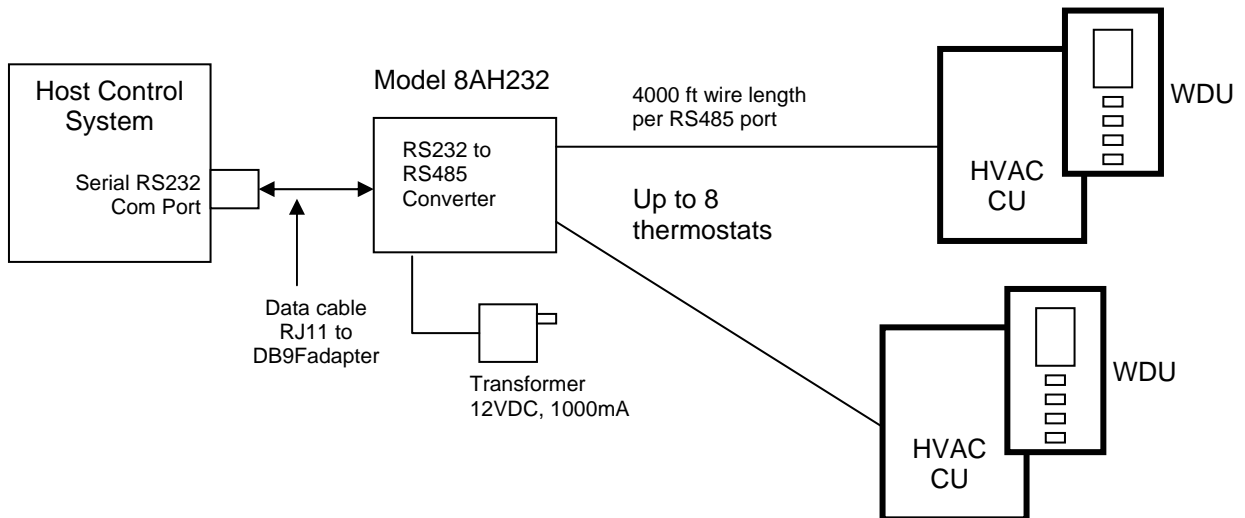

## Retrofit Applications

Existing 18Ga Thermostat Wire

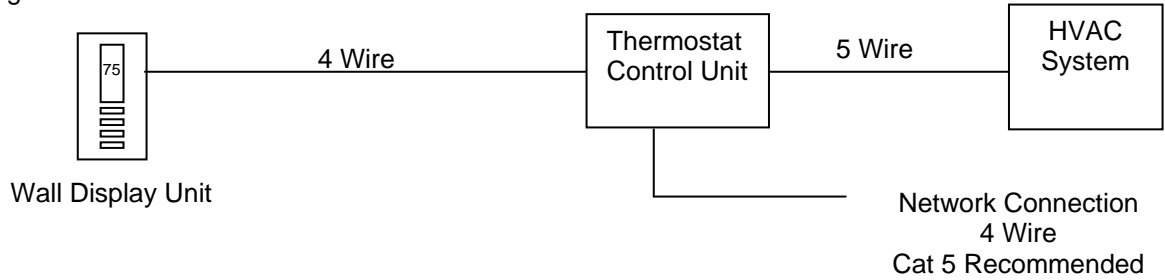

## New Construction (Option 1)

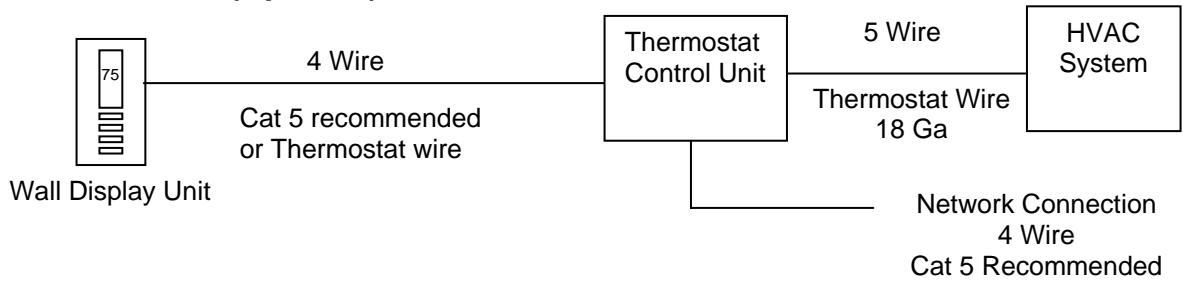

## New Construction (Option 2. Maintaining Standard Thermostat Capability)

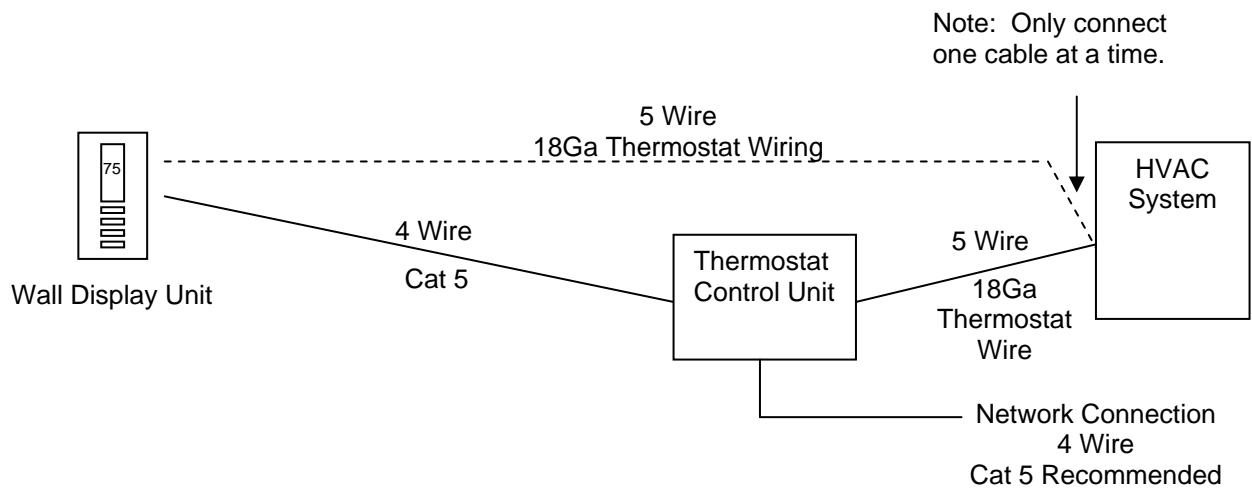

# Thermostat Network Configurations

