

RCS

HVAC Zone Control Systems

Model ZCV6

**6 Zone
HVAC Zone Control Unit**

**With RS232/RS485
Serial Communications**

INSTALLATION AND OPERATION MANUAL

DCN: 141-01068-01

2/06/06

***** IMPORTANT NOTICE *****

**DO NOT USE THIS PRODUCT FOR BUILDING FREEZE PROTECTION! YOU ARE ADVISED TO
INSTALL A MECHANICAL FREEZE PROTECTION DEVICE ON YOUR SYSTEM FOR THIS PURPOSE.**

The ZCV6 HVAC Zone Control Unit allows a single HVAC mechanical system to be divided into six fully independent zones. Zone control is accomplished with individual “thermostats” or temperature sensors in each zone and motorized zone dampers to control the flow of air to each zone.

Each zone “thermostat” is a RCS Wall Display Unit (WDU). The Wall Display Unit looks like a traditional thermostat and is the wall mounted user interface for each zone of the ZCV6 controller. It provides visual display of temperature, setpoints and modes, the control pushbuttons, and the zone temperature sensor. The WDU's connects to the Zone Control Unit by a 4 wire cable, which can be existing thermostat wires in retrofit applications or Category 5/6 wiring in new construction.

The Zone Control Unit connects to the HVAC system at the standard thermostat connections. Electrically, it functions just like a regular thermostat to the HVAC system, provides the thermostatic control of each zone and sends the appropriate heating and cooling outputs to the HVAC mechanical system.

Wall Display Units. The ZCV6 supports RCS Model TS40 and TS16 Wall Display Units. ***You must have at least one TS40 WDU on the ZCV6 for setup.*** (RCSLink2 type Wall Display Units)

Standard or Heat Pump HVAC Systems. The ZCV6 is compatible with either standard Gas/Electric or Heat Pump HVAC systems. System type is selectable. The ZCV6 is 100% Heat Pump compatible with changeover valve operation that can be selected for either changeover with cooling or changeover with heating (O or B type).

Multi-Stage HVAC Compatibility. The ZCV6 series HVAC outputs supports 2 stages of heating and 2 stages of cooling for Standard systems, and 3 stages of heating and 2 stages of cooling for Heat Pump systems.

Stage one comes on at 1 deg from setpoint, stage two comes on at 3 deg from setpoint and stage 3 heating for heat pump systems comes on at 5 degrees from setpoint. Stage 1 and 2 operation will stay on until setpoint is reached. For Heat Pump systems, the stage 3 auxiliary or heat strip heating will go off at 3 degrees from setpoint. These stage deltas can be adjusted.

Fully Independent Zones. Each zone is fully independent and can be set to any setpoint or mode. Mixed modes are allowable among the zones, that is, one zone may be set to heating while another may be set to cooling. The system is fully automatic and has auto changeover capability. Heating calls are give priority over cooling calls. The Zone Control Unit monitors the setpoint and modes of all zones and determines what Heating calls will be satisfied first and when all heating calls are satisfied, the system mode will switch to cooling to satisfy all cooling calls.

Fail Safe Zone Damper Operation. The ZCV6 uses normally open dampers for fail safe operation. In the event that zonal control is lost, all dampers are open so that heating or cooling to all zones is possible until zone control can be restored. During normal operation, when a zone calls for cooling, *all other zones not calling will be closed.* At the end of the call, all dampers will return to open. This “all zones normally open mode” also allows for system wide ventilation.

Fresh Air Venting. A vent damper relay output is provided for fresh air venting operation.

Remote Communications. The ZCV6 can be jumper selected for RS232 *or* RS485 serial communications (only one at a time). It can send and receive data and commands by serial communications to allow remote control of the system. Commands including requesting status of zone temperature, setpoint, heating/cooling mode and fan mode as well as setting any zone setpoint or mode. Individual and global zone commands are allowed. Refer to the RCS RS232/485 protocol manual.

Each Zone is assigned a network address. RCS Automation Control Units, such as the CommStar Models CS30/308/48, can support up to 32 HVAC zones.

Outside Temperature Operation

The ZCV6 can use and display outside temperature information from a sensor attached to the ZCV6 Outside Temp Sensor Input or from outside temperature data received from the network. In either case, the outside temperature will be displayed on all zone WDU's. A TS16 WDU can view the outside temperature by pressing the up/down arrows simultaneously. A TS40 WDU will show the outside temperature at the top center of the screen when outside sensor data is available.

Outside Temp Sensor Attached to the ZCV6. When a outside temp sensor is attached to the ZCV6, it is "enrolled" as an active sensor when the unit powers up and initializes. Changes in outside temperature are sent to the wall display units for local display and also reported on the network.

Reporting Outside Temperature on the Network. When an Outside Temp Sensor is attached to the ZCV6 Outside Temp Sensor Input, the outside temperature will be reported on the network in response to the Request Status message R=1. The outside temperature shows up as "OA=xx" in the status message data string.

Displaying Network Outside Temp Data. If a local outside temp sensor is **not** connected to the ZCV6, outside temperature data can be received from the network and the ZCV6 will treat it just like a local sensor is installed. ***If a local outside temp sensor has been installed on the ZCV6 it will inhibit network outside temp data from being accepted.*** This is true even if a outside sensor was enrolled and then disconnected but has not been un-enrolled by resetting the ZCV6.

Note that **network supplied** outside temp data will NOT be reported in Request Status R=1 message response (no "OA=" data will appear).

STANDARD HVAC SYSTEMS

Heat and Cool Mode Operation. In the **HEAT** mode, the heating system will be turned on when the room temperature falls one deg below the **Heating Setpoint** and will turn off when the temperature reaches the setpoint. This is referred to as the heating delta setting and is factory default set to 1 degree.

In the **COOL** mode, the cooling system will be turned on when the room temperature rises one degree above the **Cooling Setpoint** and will turn off when the temperature reaches the setpoint. This cooling delta setting is also factory default set to 1 degree.

These factory default settings can be changed from the “Installer Settings” menu on the TS40 Wall Display Unit. These variables are in the “Delta T Settings” menu item.

Heat/Cool Delta. The system requires a minimum separation between heating and cooling setpoints. This is factory default set to 4 degrees. Any attempt to change a heating or cooling setpoint that results in less than the 4 degrees separation will result in “setpoint push”. Changing a heating setpoint will push the cooling setpoint to maintain the 4 degrees separation and, likewise, changing the cooling setpoint will push the heating setpoint as needed to maintain the delta. The Heat/Cool delta can also be changed in the “Installer Settings” menu on the TS40 in the Delta T Settings selection “H/C Delta”.

Auto Mode Operation. In the **AUTO** mode, the system will automatically switch between heating or cooling modes as needed to maintain the heat/cooling setpoints.

STANDARD HVAC SYSTEM STAGING

For Standard HVAC system types, the ZCV6 has two stages of heating (W1 and W2) and two stages of cooling outputs (Y1 and Y2). The second stage heating or cooling will come on when the room temperature is 3 degrees from setpoint and will turn off when the temperature reaches the setpoint.

The Second Stage Deltas are factory default set to 3 degrees but can be changed from the “Installer Settings” menu on the TS40 Wall Display Unit. These variables are in the “Delta T Settings” menu item.

HVAC SYSTEM TYPE SELECTION

HVAC systems are generally “Standard” type, which are gas or electric heating systems coupled with compressor cooling or “Heat Pump” type which use reversible compressors for both heating and cooling. The ZCV6 works with either HVAC system type. The HVAC system type is set by dipswitch SW1, switch position S1 on the ZCV6 controller board.

The ZCV6 Control Unit is factory default set to Standard HVAC system type (SW1-S1 OFF)

HVAC SYSTEM FAN MODE SELECTION

Standard HVAC systems using GAS heating DO NOT require fan control outputs from thermostats when in the heating mode because the furnace automatically turns on the system fan when the system heats up.

Standard HVAC systems using ELECTRIC heat strips for heating DO require fan control outputs from thermostats during heating calls.

The fan mode selection is set by dipswitch SW1, switch position S2 on the ZCV6 controller board.

The ZCV6 Control Unit is factory default set to “GAS” system type fan mode. (SW1-S2 OFF)

If you have a Standard HVAC system with ELECTRIC heating, the fan mode must be set to “ELEC” mode which is dipswitch SW1 position S2 ON.

Be sure to check your HVAC system’s requirements.

HEAT PUMP HVAC SYSTEMS

HEAT PUMP SYSTEM OPERATION

Heat Pump HVAC Systems use the system's compressor for both heating and cooling. The system reverses the compressor operation to change heating/cooling mode. In addition, Heat Pump HVAC systems may have Auxiliary Heat (heat strips) stages.

Heating and Cooling Mode Operation. Heat Pump HVAC systems work the same as Standard systems for Stage 1 and Stage 2 heating and cooling operation. Delta T settings are the same and change be changed the same way as Standard systems.

Heat/Cool delta and Auto mode operation is also the same as Standard systems.

HEAT PUMP SYSTEM STAGING

The ZCV6 has 3 stages of heating and 2 stages of cooling for Heat Pump HVAC systems. Stage one and stage two heating are Y1 and Y2 outputs. Stage 3 heating is auxiliary heat and is the W1 output. Stage one and stage two cooling are also the Y1 and Y2 outputs, with heating/cooling mode determined by the reversing valve (also call the changeover valve) O output. ()

The third stage of heating will be turned on when the current temperature falls 5 deg below the current setpoint and will turn off at 3 degrees below the setpoint. The Delta T settings can be changed from the "Installer Settings" menu on the TS40 Wall Display Unit. These variables are in the "Delta T Settings" menu item.

HVAC SYSTEM TYPE SELECTION

The HVAC system type is set by dipswitch SW1, switch position S1, on the ZCV6 controller board.

To set the ZCV6 for Heat Pump HVAC system type, set the dipswitch SW1-S1 to HP (SW1-S1 ON).

CHANGEOVER VALVE OPERATION SELECTION. Heat Pump systems change from heating to cooling mode by reversing the direction of refrigerant flow in the system. This "changeover" is controlled by the reversing valve or changeover output (a shared output marked W2/O) from the Control Unit.

Most Heat Pump HVAC systems are designed to work normally in the heating mode and require a change over output for cooling. Dipswitch SW1 is used to

The ZCV6 is factory default set for Changeover with cooling (SW1-S2 OFF)

Set CO SEL switch SW1-2 to CO/CL (default) for this type system. Check your HVAC system requirements for correct settings. If your system requires change over with heating, set SW1-2 to CO/HT. The changeover relay will stay on until the MOT expires before dropping out. If another call commences before the MOT timeout, it will avoid unnecessary cycling of the changeover valve.

Minimum Run Time (MRT)

The ZCV6 control unit has a Minimum Run Time after the start of any heat or cool call. This 6 minutes minimum run time assures even heating and cooling cycles. Minimum Run Time will keep the system on, even if you change the setpoint to a temperature that would satisfy the call, until it expires. Changing the Mode to OFF will cancel the MRT and the system will turn off immediately.

Minimum Off Time (MOT)

The ZCV6 control unit has a Minimum Off Time after any heat or cool call. This 6 minutes delay prevents rapid heating/cooling cycles and also provides "short cycle protection" for compressor calls. This delay may be noticeable when you change a zone setpoint and it does not respond immediately due to another call have been recently completed and the MOT delay timer is still active.

The ZCV6 HVAC controller has the option for either RS-232 or RS-485 serial communications. The serial port allows remote commands generated by other systems to be received by the ZCV6. These remote commands can change the individual zone setpoint, temperature and modes or may request current status of a zone temperature, setpoint and mode. Remote commands received by the ZCV6 to change a zone setpoint or mode are sent to the zone WDU to update its display. Whenever new commands are received, the WDU will switch its display to show the updated information for three seconds and then return to the current temp display.

RS-485 connections are a twisted pair multi-drop network that can have up to 254 devices connected to one pair of wires. With use of a RCS Star Wiring Hub, wiring can also be “star” or “homerun” from each connected device to the host system, such as RCS CommStar network control units.

Network Addressing. The RS485 address is set from the Wall Display Unit. Network address 0 is reserved for the Host control unit and address 255 is reserved for global commands.

Each zone in the ZCV control unit is treated like a separate thermostat and has its own RS485 address. When you set the address for the control unit, you are setting the **base address for Zone 1**. Each zone is sequentially addressed from this number. Note that zone addresses are assigned to all zones on the zone controller, even if they are not used.

For example: with the ZCV6 network address set to 1, each zone address is as follows:

Zone 1 = network address 1
Zone 2 = network address 2
Zone 3 = network address 3
Zone 4 = network address 4
Zone 5 = network address 5
Zone 6 = network address 6

WDU's can be set to any address from 1 to 254, as a group.

Communications Parameters. The ZCV6 serial communications setup is 9600 baud, no parity, 8 data bits, 1 stop bit and no flow control.

The RS485 port connects to the J9 screw terminal connector. The D+ and D- connections are required. The ground connection is optional, but can improve long distance communications and may be needed when the host and ZCV6 are powered from different power sources.

The RS232 port connects to PC style Com ports using the serial cable and DB9 adapter provided.

Communications Protocol

The ZCV6 Zone Controller uses the RCS serial communications protocol for HVAC control devices. It is fully compatible with the RCS CommStar Automation Controllers, such as Models CS30/308 or CS48.

The communications protocol is an ASCII message protocol. Refer to the RCS RS-232/485 communications protocol document, PN: 150-00225, for detailed information on serial commands to communicate with the ZCV6 HVAC control units.

Note that not all commands in the protocol document are applicable to or supported by the ZCV6. The protocol document has an appendix that identifies specific ZCVx series commands.

LOCATION AND MOUNTING

Install the Control Unit in a protected, convenient, INDOOR location near the HVAC system or in a service accessible area such as an equipment closet or garage.

Mount the Control Unit in a vertical position on a wall or sturdy structural member. The unit may be mounted on the HVAC system but care should be taken to avoid the hot burner section or high vibration areas.

WIRING

Wiring To The Wall Display Units

Wire specification: 4 conductor, 18Ga thermostat wire, 22Ga twisted pair or Cat 3/5 wire (preferred)

The Control Unit connects to each zone's Wall Display Unit or Sensor by four wires. In retrofit applications, the existing thermostat wiring may be used, however, for best results and in new construction, a Category 5 twisted pair cable is recommended.

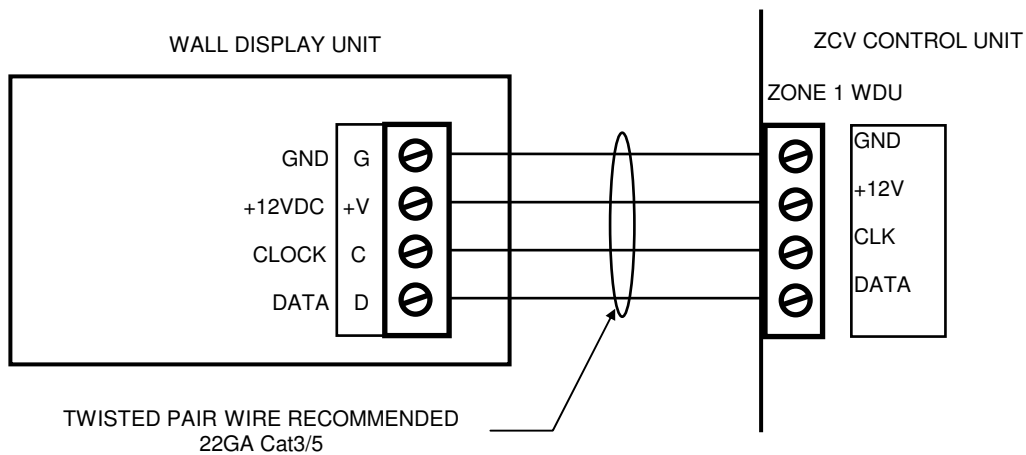

CAUTION! Do not mis-wire the Wall Display Units – damage may result. Check the wiring before applying power to the Control Unit.

Wiring To The Outside Temp Sensor (if installed)

Wire specification: 2 conductor, 22Ga twisted pair or Cat 3/5 wire (preferred)

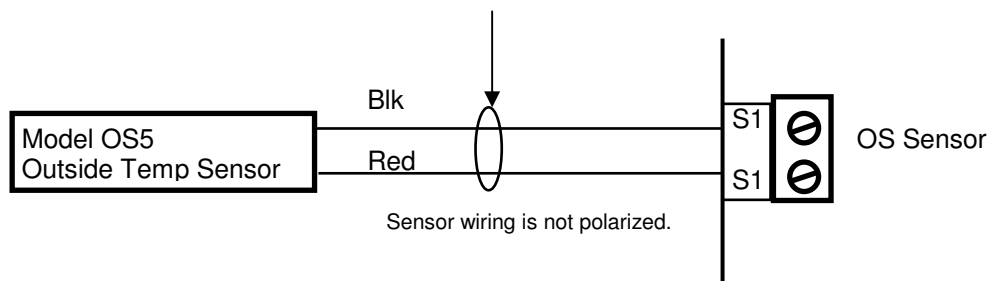

Wiring To The Zone Dampers

Wire specification: 2 conductor for RD or 3 conductor for RDM series dampers, standard 18/20GA thermostat wire.

The ZCV6 HVAC Control Unit has zone damper output relays plus a fresh air vent damper output. These SPDT relays are rated at 1 Amp, 24VAC. Zone outputs support either two wire (normally open, power close/spring return) or three wire dampers (power open, power close).

Two Wire Damper Wiring

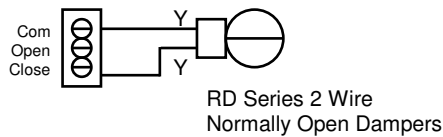

Three Wire Damper Wiring

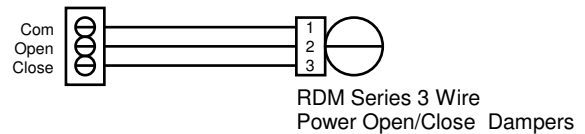

ZONE DAMPERS

The ZCV6 requires Normally Open dampers. Without any heat/cool calls, all dampers are open. When a zone calls for heat/cooling, the other zones NOT calling are closed.

This provides two important functions. First, if there is a zone output failure, the zone is still capable of getting heating or cooling. Second, it allows for ALL zone ventilation during periods of no heating or cooling (continuous fan mode).

RCS Round Motorized Dampers

xxRDNO series round motorized dampers. xx = damper size from 6 to 16 inches. These standard dampers feature an extra rigid barrel with a self sealing blade that provides a 99% seal. They are 24VAC, 2 wire, 2 position, power close/spring return, normally open dampers. Current draw is 0.5 amps each. Rated for continuous power in the closed position.

xxRDMNO series round motorized dampers. xx = damper size from 6 to 20 inches. These heavy duty style dampers have the same extra ridge barrels of the RD series, coupled with a commercial heavy duty 3 wire damper motor. These wire as 24VAC common, power open and power close. Current draw is 0.1 amps max each. Rated for continuous power in the open and closed positions.

The xxRDMNO dampers are the preferred damper for use with the ZCV6 control unit.

POWER

The Control Unit requires 24VAC Power. Power is provided by an external transformer (not supplied).

You must calculate the size of the transformer VA rating for the maximum number of dampers powered at one time. The worst case load is when only one zone calls and all others are powered close.

Each RD series damper draws 0.5 amps when closed. Each RDM series damper requires 0.1 amps and is powered in both open and closed positions.

A 40VA transformer supplies 1.67 amps and supports three RD series dampers or 15 RDM series dampers.

A 75 VA transformer supplies 3.125 amps and supports 6 RD series dampers.

Communications Setup and Wiring

RS232 Communications

When the RS232 communications mode is selected, the ZCV6 COM Port is a standard PC compatible serial port.

RS232 COM Port Setup

The RS232 communications parameters are 9600 baud, no parity, 8 data bits, 1 stop bit (9600 N81). Set Flow Control to None.

NOTE: RS232 communications still requires that a network address of 1 be assigned to the ZCV6 even though only one control unit can be attached via RS232. Individual zones must be addresses 1 to 6 for RS232 communications (default address).

Refer to the RCS Serial Protocol Manual for more information on serial communications and commands for the ZCV6 control unit.

Selecting RS232 Communications Mode

Set jumpers JP1 and JP2 on the Communications PCB to RS232 Mode (jumpers to the left).

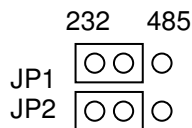

Connecting to RS232 PC Style Com Ports

A serial cable is provided with the ZCV6 for connection to the J10 RJ45 connector on the ZCV6 and to a DB9 adapter that connects to a PC style com port.

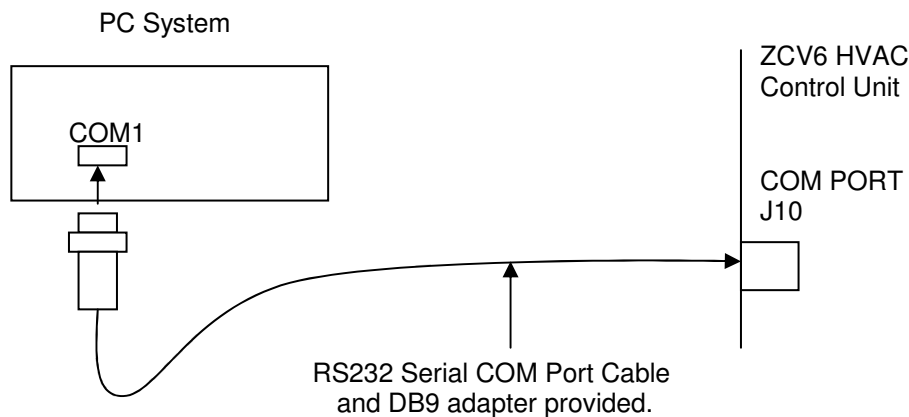

RS485 Communications

When the RS485 communications mode is selected, the ZCV6 COM port is a 2 wire (D+ and D -) plus ground, half-duplex network connection.

RS485 COM Port Setup

The RS485 communications parameters are 9600 baud, no parity, 8 data bits, 1 stop bit (9600 N81). Set Flow Control to None.

RS485 Communications Mode Selection

Set jumpers JP1 and JP2 on the Communications PCB to RS485 Mode (jumpers to the right).

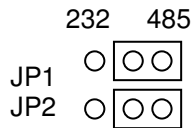

RS485 Wiring Methods

The ZCV6 control unit can be wired by three methods:

1. Direct connection to RS485 com ports
2. Multi-drop (daisy chained) to other thermostats/devices
3. Homerun wired to a Star Hub.

Direct Connection

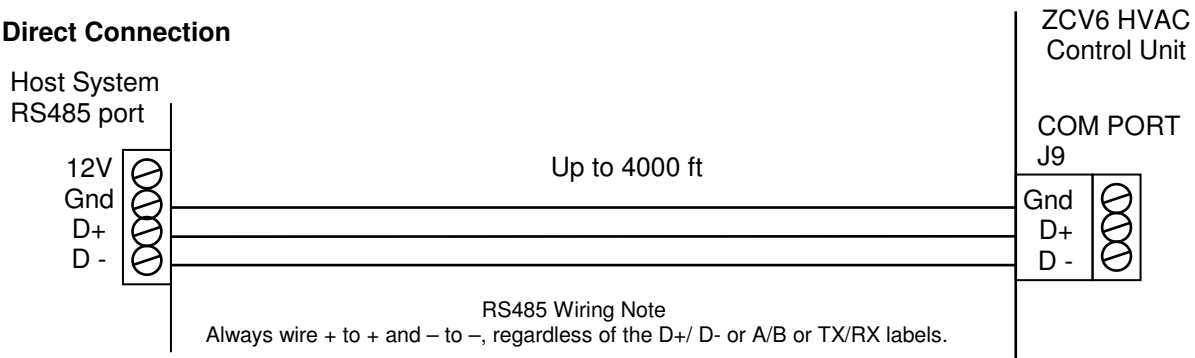

Multi-drop Wiring

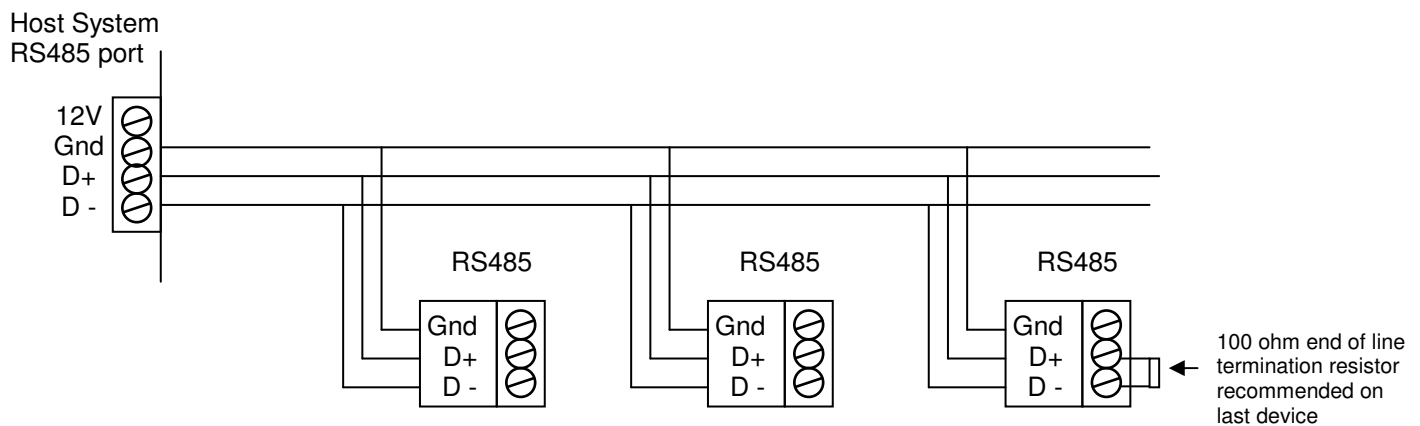

Termination Resistor

On multi-drop network wiring, the last device on the network is typically installed with an “end of line” termination resistor. This may not be needed for short networks, but if your line length exceeds 1000 feet, you may benefit from this termination to keep network reflections to a minimum.

The ZCV6 can be jumper to provide a 100 ohm end of line termination resistor.

Jumper JP3 on the communications PCB to enable this resistor.

Star Hub Wiring

Star networks are home run wiring and may be used with the RCS CommStar CS308 Automation Controller, or added to other controllers with the Model 8AH485 RS485 Star wiring hub. Star wiring is simple and easy to install and trouble shoot.

CommStar Model CS308
or Model 8AH485
8 Channel Star RS485 Hub

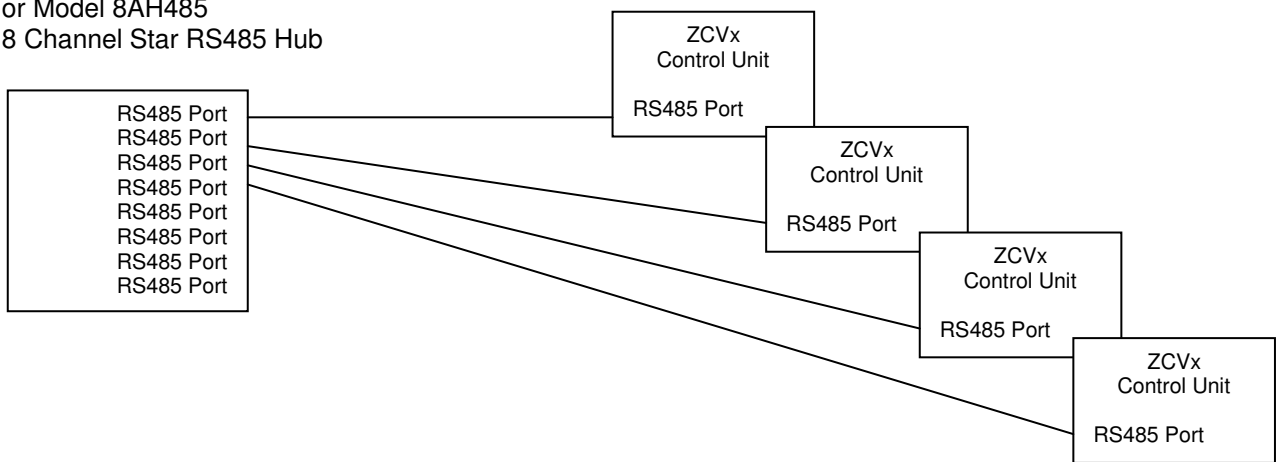

HVAC SYSTEM WIRING

Electrically, the ZCV6 Control Unit looks like a standard thermostat to your HVAC system. All connections to the HVAC systems are made at the normal thermostat connection on the HVAC unit.

Refer to the following HVAC wiring information for the type of HVAC system, Standard or Heat Pump, that the ZCV6 control unit is being connected to. Refer to your HVAC system's documentation for specific information on its thermostat connections.

Standard Gas/Electric HVAC System Wiring

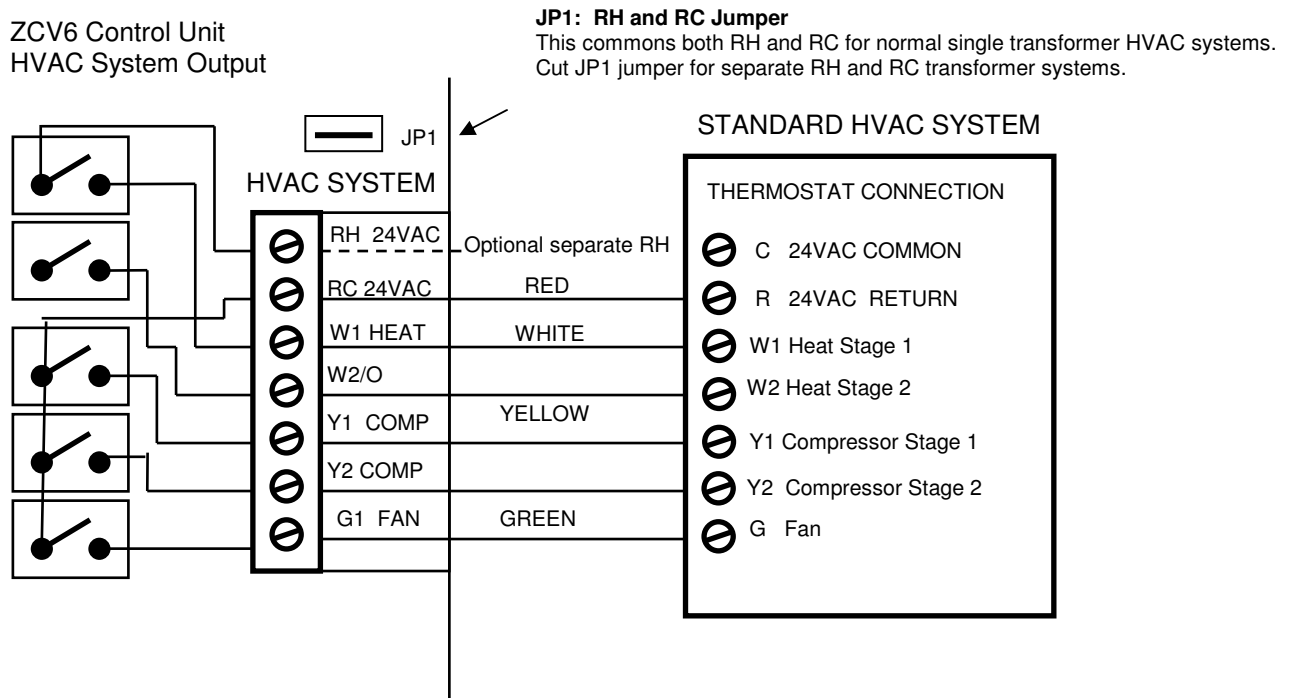

Heat Pump HVAC System Wiring

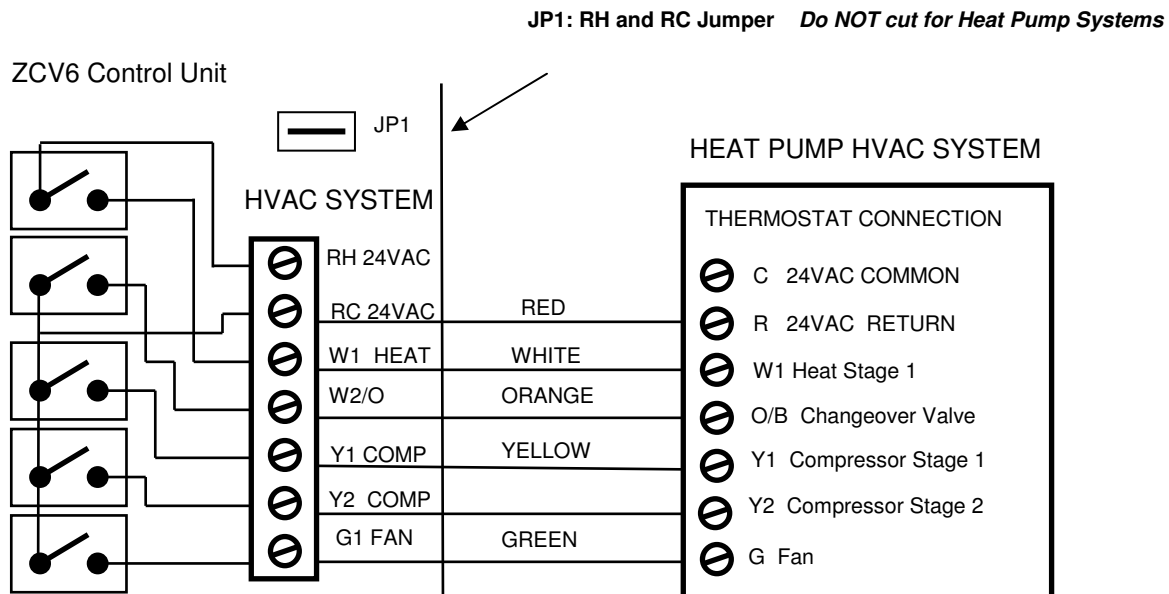

SYSTEM CHECKOUT

It is strongly recommended that you hook-up and run a simple bench test before installing this controller. Not only will this save you time in system checkout but will also familiarize you with the ZCV6 operation.

QUICK TEST

NOTE: Before power up, set the dipswitch on the controller PCB, SW1, to ALL OFF.

1. Connect a Wall Display Unit to ZONE 1 input on the Control Unit with a short 4 wire cable.
2. Connect the 24VAC transformer to the Control Unit.
3. Plug the transformer into a 110v outlet and apply power to the Control Unit.
4. Verify Power Status LED is **flashing**.
5. Verify the WDU display comes on and shows the current temperature.
 - a. If no display or a "CF" display is shown on the WDU, **double check your wiring**.
 - b. Do not proceed until the current temperature is displayed on the WDU and communications between it and the Control Unit is OK. Any problems will result in a "CF" (Communications Failure) display on the WDU.
6. Press the Fan button on the WDU. The Control Unit Fan LED and relay should turn on. Also all damper LED's should turn on except Zone 1.
7. Press the Fan button again. The Fan LED and all relays should turn off.
8. Press the Mode button until the WDU is showing "H" for Heat Mode.
9. Press the Setpoint Up button until the setpoint is above the current temperature. The Heat LED and relay should come on.
10. Press the Mode button until the WDU is showing "O" for OFF. The Heat LED and relay will turn OFF.
11. Press the Mode button until the WDU is showing "C" for Cool Mode.
12. Press the Setpoint Down button until the setpoint is below the current temperature. The Cool and Fan LEDs and relays should turn on.
13. Press the mode button until the WDU is showing "O" for OFF Mode.
14. All LEDs and relays should turn off.
15. When you have successfully completed all these tests, you have verified that the Control Unit and the WDU are working and communicating correctly.

RS-232 QUICK TEST with a PC

1. With the Control Unit and WDU connected as above, proceed with connecting the ZCV6's com port to a PC serial port (COM1). Set the ZCV6 com port to RS232 mode by setting the jumpers on JP1 and JP2 to the right.
3. Set the ZCV6 base address to 1
4. Start the Hyperterm terminal emulator program in Windows/Accessories/Communications/Hyper Terminal.
5. Set Hyperterm communications parameters for COM1 to 9600 baud, no parity, 8 data bits, 1 stop bit and NO flow control.
6. **Set CAPS lock on (Commands are case sensitive).**
7. Send the Request for Status command R=1. Type "A=1 R=1" followed by the carriage return (cr).
8. ZCV6 should respond with the R=1 status response showing temp, setpoint, mode and fan for zone 1 (A=00 O=1 Z=1 T=(current temp) SP=70 M=0 F=0)
9. Set zone 1 Mode to Heat. Type "A=1 M=H (or 1) cr".
10. Zone 1 WDU should change to show the new mode is "H".
11. Set zone 1 setpoint to 78 degrees. Type "A=1 SP=78 cr"
12. Zone 1 WDU should change to show a setpoint update of "78".
13. If the WDU responds properly to these commands, proceed with installation.

It is recommended that you install the ZCV6 and then rerun these quick tests BEFORE you connect the Control Unit to the HVAC system. You will be confident that the ZCV6 is working correctly before you attempt to interface the HVAC system.

HVAC SYSTEM QUICK TEST

In the event that you have difficulty with the ZCV6 controlling the HVAC system, you can perform the following quick test to confirm that the HVAC system is working correctly.

The ZCV6 Control Unit connects to the HVAC system at the **normal thermostat connections** on the HVAC unit. Standard thermostat control of the HVAC systems consist of contact closures in the thermostat. You can verify that your HVAC system is working correctly by duplicating these contact closures by shorting across the proper terminals on the HVAC systems thermostat connection. Refer to the following HVAC system example.

HVAC SYSTEM EXAMPLE

This is a simplified diagram of an HVAC System and Thermostat. The Thermostat operates like switches to control the HVAC Fan, Heat, and Cool functions.

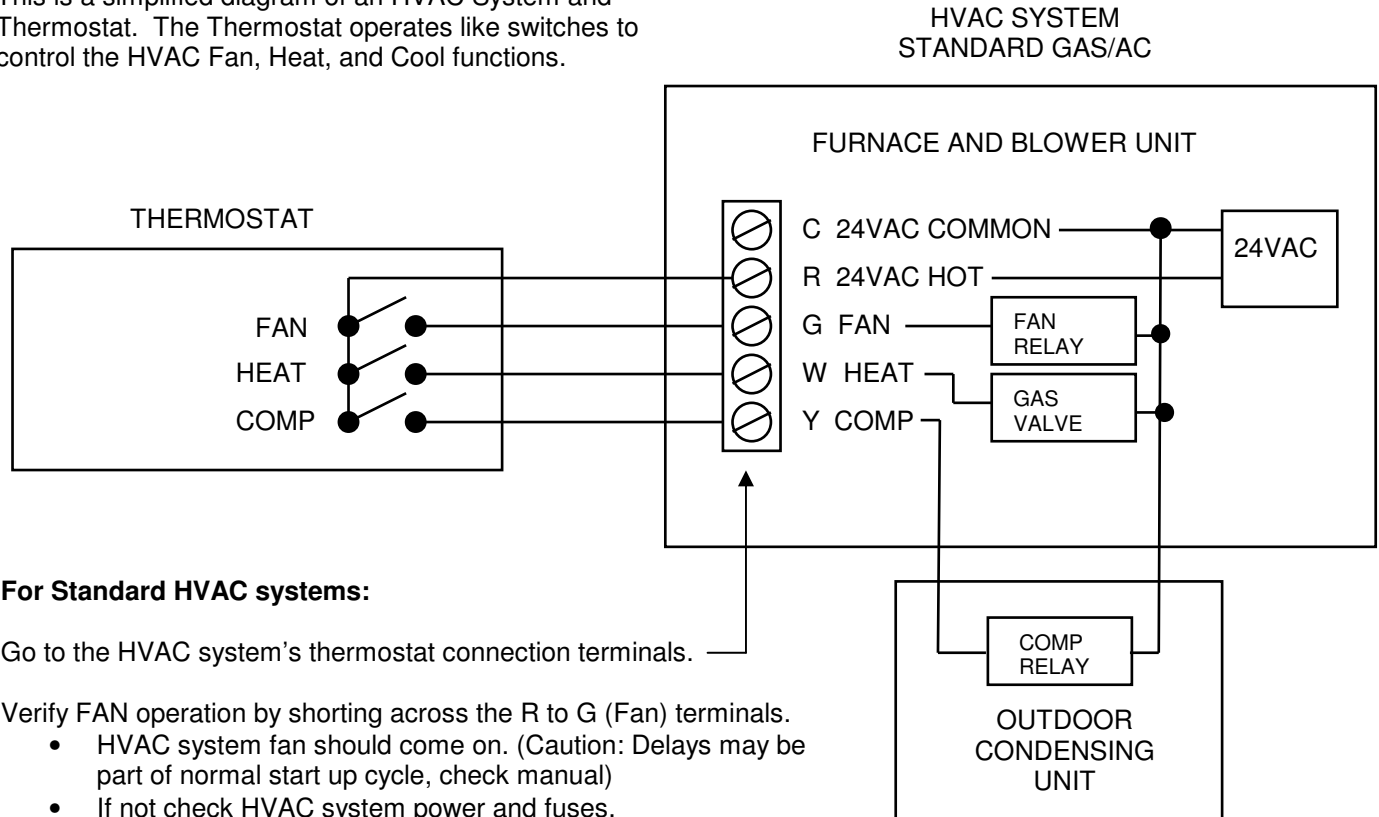

For Standard HVAC systems:

Go to the HVAC system's thermostat connection terminals.

Verify FAN operation by shorting across the R to G (Fan) terminals.

- HVAC system fan should come on. (Caution: Delays may be part of normal start up cycle, check manual)
- If not check HVAC system power and fuses.
- If power is OK, HVAC system is NOT working correctly.

Verify HEAT operation by shorting across R to W (Heat) terminals (A Fan call is not necessary for gas furnaces).

- Heating operation should start. (Caution: Delays may be part of normal start up cycle, check manual)
- If not, check wiring, check 24VAC power is on R terminal. (measured across R to C).
- If power is OK, HVAC system is NOT working correctly.

Verify COOL operation by shorting across R to Y (Compressor) and R to G (Fan) terminals.

- Cooling operation should start. (Caution: Short Cycle Protection 5 minute delays are normal between calls and may delay start)
- If not, check wiring, check 24VAC power is on R terminal (measured across R to C)
- If power is OK, HVAC system is NOT working correctly.

For Heat Pump systems:

Follow the above test to check the FAN operation. If FAN works OK, then power is verified also.

Short across R to Y and R to G. You should get either Heat (normal) or Cool operation depending on the whether your system is changeover with cool (normal) or heat.

Short across R to Y, R to G and R to O/B(Changeover terminal) to get opposite heat or cool operation from step 2. **If any of these checks fail, the HVAC system is not working correctly.**

ZCV6 6 ZONE HVAC CONTROL UNIT

Wiring Diagram

